

Wood boilers



Heating systems ◀

Industrial systems

Refrigeration systems



## Heating with wood – the most natural fuel in the world

The rising cost of fossil fuels and growing environmental awareness have led to a steady increase in demand for renewable forms of energy. On the following pages, we will provide you with comprehensive information about efficiently burning wood, a sustainable fuel, in advanced boilers.

A wood boiler is a good alternative to heating with oil or gas. Alongside environmental considerations, there are also economic reasons for relying on wood. As an indigenous fuel, wood is very cost efficient and not subject to extreme price fluctuations.

Thanks to advanced Viessmann technology, heating with wood is now both efficient and convenient. Whether you are looking for an auxiliary appliance or a complete heating system, the Viessmann range offers flexible solutions, fired with logs, wood pellets or woodchips, depending on the type of boiler.



## About this brochure

Viessmann wood boilers meet the demand for an efficient and economical heating system. This brochure provides information about our current range and contains plenty of useful facts about accessories, service, available subsidies and finance options.



### Saving energy and protecting the climate

from page 6

Find out why it is worth modernising your heating system now, so you can make an active contribution towards protecting the climate and using less fossil fuel.



### Key facts

from page 8

Wood reaches its highest calorific value after being stored for several years in a well-protected place. If you heat with wood or wood pellets, there are certain points to bear in mind regarding purchase and storage.



### The Vitoligno range

from page 10

With Vitoligno wood boilers, all options for combustion with logs and wood pellets are available to you. There are a number of different models with an output range from 8 to 170 kW to choose from.



### System technologies designed to work together

from page 30

Use the most advanced system technology to control your heating system. Individual control options provide optimum operating convenience and economical operation.



### Service that covers every aspect of heating

from page 38

Viessmann trade partners can tell you all you need to know about tailor-made heating technology, available subsidies and finance options, without obligation and free of charge.



### The company

from page 40

The power of innovation: Today, as a third generation family run business, Viessmann offers state of the art technology and takes responsibility for making it work.



# Saving energy and protecting the climate

Viessmann is aware of its responsibilities towards the sustained protection of the environment. Our company philosophy and products have been constructed with this duty in mind.



"Nothing is so good that it cannot be improved". This motto is also reflected in our company principles. Viessmann can rightfully claim to be the leader in quality and technology, and as such, aims to continually set new standards.

Of course, this applies in particular to the company's product range, which is consistently geared towards significantly lowering the consumption of fossil fuels and gradually replacing them with renewable sources of energy.

At around 40 percent, the heating sector actually accounts for the largest proportion of energy consumption. The rest is shared by freight, personal transport and power generation, each accounting for 20 percent. These values can also be applied approximately to other industrial countries. Ever-rising energy costs mean that the emphasis is on reducing the consumption of fossil fuels as quickly as possible.

## Wood is a good alternative

Based on today's energy prices and taking into account the overall investment outlay, a wood heating system is a viable alternative. Viessmann wood boilers are highly efficient and economical in their fuel consumption.

Viessmann wood boilers are suitable both as the sole heat generator and as a supplement to oil or gas boilers. By installing a wood boiler, spending on oil and gas is reduced significantly so the boiler starts paying for itself almost immediately. You will be making a positive contribution towards the sustainable protection of our climate, as heating with wood is CO<sub>2</sub> neutral. This means that only as much carbon dioxide is released into the atmosphere as the wood absorbed while it was growing.

Viessmann has the right solution for you.

Viessmann offers energy saving heating systems for all applications and fuel types.

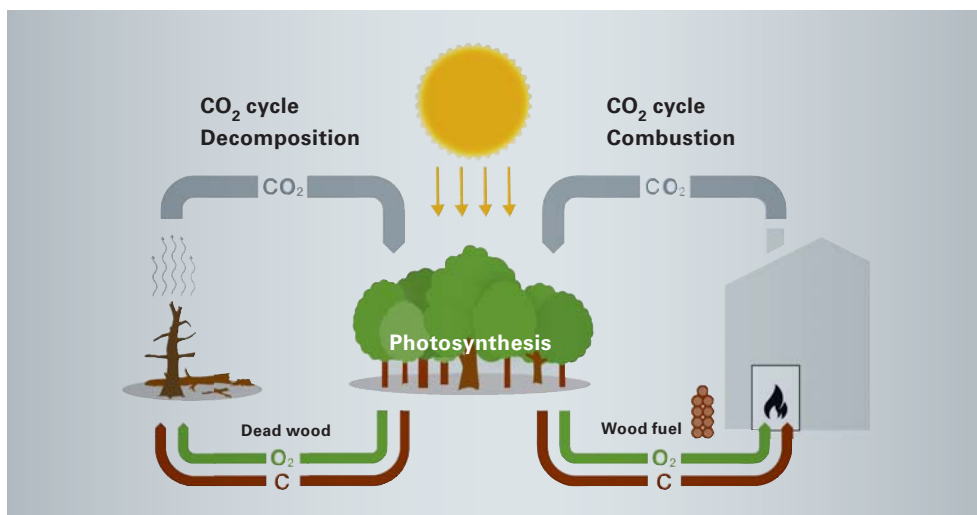

Wood energy – Sustainable and CO<sub>2</sub> neutral

## Key facts

Wood heating systems are offered for a wide range of wood fuels. See below for information about the properties of this fuel and how it should be stored.

### Storage of split logs

The combustion of moist wood is not only uneconomical, it can also lead to high emissions and tar deposits inside the chimney stack due to low combustion temperatures. Wood reaches its highest calorific value after being dried for at least three years in a well-protected place.

#### Here are a few tips:

- Split round logs with a diameter of 10 cm or more
- Stack the logs in a ventilated and preferably sunny spot underneath a rain canopy
- If possible, stack logs with generous air gaps to enable flowing air to absorb the dissipating moisture
- Stack logs on a support timber so moist air can escape
- Never store freshly cut wood in a cellar, as air and sunshine are required for drying. However, dry wood can be stored in ventilated cellars.

### Woodchips – a standardised quality fuel

Certain quality parameters should be borne in mind when selecting a suitable fuel for a woodchip system. Fuel standard EN ISO 17225-4 should therefore be consulted when purchasing woodchips. This standard refers explicitly to the use of woodchips in small boilers and examines, amongst other things, different particle sizes and fuel quality classes.

### Properties of wood pellets

Only 100 percent untreated wood remnants are used in the manufacture of wood pellets to ENplus and EN ISO 17225-2 standards. This raw material consists of waste matter created by the wood processing industry in large volumes through planing or sawing.

Fine grained wood remnants are compressed under high pressure and formed into pellets, i.e. pressed into a cylindrical shape. The fuel is dry for storage and transport. Completely dry storage conditions are absolutely essential. This is the only way to guarantee optimum and effective combustion.

Wood pellets are offered in packs and in bulk. In their loose form, wood pellets are transported by silo tanker and pumped into the pellet store via a hose system.

If an oil heating system is to be completely replaced with a new pellet heating system, the room in the cellar used previously to store fuel oil is ideally suited for this purpose.



## Questions regarding wood boilers

Viessmann is aware of its responsibilities towards the sustained protection of the environment. Our company philosophy and products have been constructed with this duty in mind.

### Can anyone heat with a wood boiler?

Viessmann wood boilers are so convenient to use that they can supply practically any house or apartment building with heat. One important requirement is a dry pellet store, as the residual moisture in the wood is one of the crucial factors influencing the combustion quality. Conversions, for example of the chimney stack, are generally not required. Wood heating systems from Viessmann are also a perfect companion for oil and gas heating systems.

### What is better – heating with logs or wood pellets?

Logs are an ideal choice for those who can acquire the fuel themselves, for example from local forestry operations. Wood needs to be seasoned correctly, in other words stored until it has the lowest possible residual moisture content. In addition, a heating water buffer cylinder is required to ensure a continuous supply of heat.

Wood pellets are made from sawdust and created under pressure. Due to their low residual moisture content they have a high net calorific value. Wood pellets are easy to deliver and store. Supplying and charging them to the wood heating system is automatic and convenient.

### Where can I obtain wood fuel?

Wood fuels, especially wood pellets, are now standard fuels for most fuel merchants. As with fuel oil, they are "pumped" into the pellet store. This is accomplished quickly and without much effort. Many sawmills and wood processing enterprises also offer wood pellets. You can obtain logs and woodchips at favourable prices from forestry operators or farms with forestry enterprises attached.



#### Logs

Logs are pieces of wood (hard and softwood) from forestry operations and countryside management.



#### Wood briquettes

Wood briquettes are compressed wood remnants. The size and density of wood briquettes must be matched to the charging system used.



#### Wood remnants

Wood remnants are very diverse in terms of consistency and size; the remnants come as a mix of hard and softwoods.



#### Woodchips

Woodchips are small pieces (e.g. chips) of natural wood, with or without bark. The relevant fuel standard is EN ISO 17225-4.



#### Wood pellets

Wood pellets are the most compact form of wood-based energy and have a high net calorific value. Ensure that the pellets used conform to standard branded quality (such as ENplus-A1 or EN ISO 17225-2 quality class A1).



## The Vitoligno range

Logs, wood pellets or woodchips – the Vitoligno range has everything covered.

Auxiliary or complete heating system, in conjunction with logs, wood pellets or woodchips – Viessmann offers the full product range for heating with wood.

By choosing a Vitoligno wood boiler, you'll always be on the safe side, as there are so many reasons in its favour:

- Saving on energy costs and protecting the climate (CO<sub>2</sub> neutral)
- The economical and sustainable alternative for greater independence
- Renewable – a natural fuel
- Independence from oil and gas
- Clean and efficient combustion
- Can be used in mono mode, dual mode or even as a system solution



### Vitoligno 300-C

Pellet boiler

8 to 12 kW

**Page 12**

18 to 48 kW

**Page 14**

60 to 101 kW

**Page 16**



### Vitoligno 200-S

High performance wood gasification boiler for logs up to 50 cm long, 20 to 50 kW

**Page 18**

### Vitoligno 150-S

Log gasification boiler for logs up to 56 cm long, 17 to 45 kW

**Page 20**



### Vitoligno 250-S

Log boiler for manual charging with logs, wood briquettes and wood remnants  
Hopper width  
550 mm: 40 to 75 kW  
1080 mm: 85 to 170 kW

**Page 22**



### Vitoligno 250-F

Wood boiler for manual charging with logs and wood briquettes, wood pieces and loose wood remnants, as well as for automatic charging with wood pellets and woodchips.

49 to 100 kW

**Page 24**

## Pellet boiler

### Vitoligno 300-C 8 to 12 kW



Compact, fully automatic  
Vitoligno 300-C pellet boiler



The pellet box can be positioned  
right next to the Vitoligno 300-C  
or, if preferred, anywhere inside  
the room.



Convenient operation via  
Viessmann app and smartphone

#### Compact, fully automatic pellet boiler for new and existing installations

The compact Vitoligno 300-C pellet boiler is an efficient solution for new build and for existing buildings of low energy standard. In the output range of 2.4 to 8 or 2.4 to 12 kW, the pellet boiler modulates with a ratio of 1:3 and features impressively low energy consumption. Operating the Vitoligno 300-C is extremely easy, making heating with wood pellets highly convenient. Almost everything is automatic – from charging with wood pellets right through to cleaning.

#### Compact dimensions for flexible siting

The pellet boiler allows flexible and space efficient siting as all components are directly accessible for service and maintenance. One ideal option is to install it in the corner of the boiler room. Viessmann offers a complete range of accessories for pellet storage and transport from a single source.

#### Convenient automatic functions

Wood pellets burn with few residues – and even these are taken care of automatically by the Vitoligno 300-C. Fully automatic cleaning of the finned grate in the combustion chamber at least once a day. This guarantees low losses and excellent fuel utilisation.

Automatic ash removal compresses the ash in the ash box and ensures that it needs to be emptied no more than twice a year. Due to the fact that the ash box is sealed, ash removal is also clean and stress-free.

#### Flexible fuel feed

In the delivered condition, the Vitoligno 300-C is equipped with a vacuum system for automatic pellet discharge from the pellet store as standard. The Vitoligno 300-C can be converted quickly and easily from automatic to manual charging. Commercially available bags of wood pellets can be used for manual charging if necessary, e.g. if there is insufficient space for a pellet store.

#### Matching accessories

For pellet stores, a modular 4- or 8-way wand changeover is available. It is regulated by the Ecotronic and ensures an even discharge of pellets from the pellet store by changing the wands over automatically. Installation of the wand system is flexible and suitable for a wide range of different storage spaces. It ensures optimum use of the pellet store.

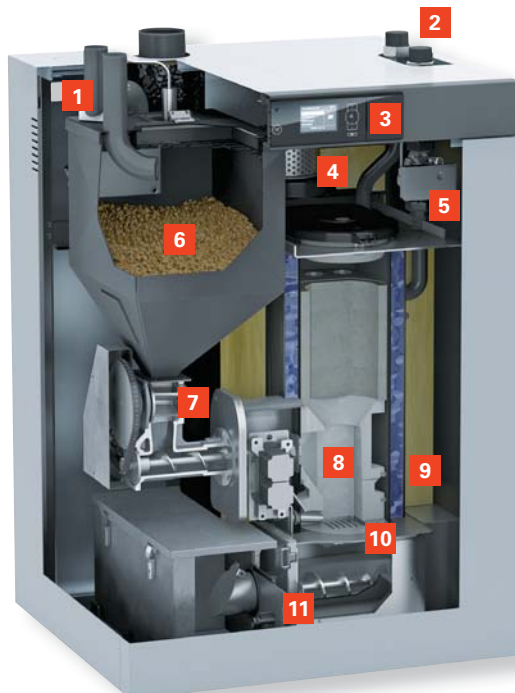

#### Vitoligno 300-C

- 1 Integral suction turbine with connection for supply and return hose
- 2 All connections at the top – optional corner installation
- 3 Ecotronic control unit with user prompts
- 4 Variable speed flue gas fan for modulating operation
- 5 Built-in regulated return temperature raising facility with high efficiency pump
- 6 Pellet hopper for 32 kg of fuel
- 7 Rotary lock valve for 100 % burn-back protection
- 8 Combustion chamber made from high temperature-resistant ceramics
- 9 Highly effective thermal insulation
- 10 Self-cleaning finned grate made from stainless steel
- 11 Automatic ash removal with large ash box



Compact and fully automatic Vitotigno 300-C pellet boiler for buildings with good thermal insulation and limited heat demand (e.g. low energy houses)

For manual charging from pellet sacks, the pellet box can be positioned right next to the Vitotigno 300-C or, if preferred, anywhere inside the room. A 260 kilogram load is sufficient for up to ten days.

#### Intelligent Ecotronic control unit

Operating the Vitotigno 300-C is easy with the weather-compensated digital Ecotronic control unit. Up to three heating circuits can be controlled with the standard version. The boiler with pellet supply, the heating circuits and the cylinder temperature can all be controlled intuitively. Adjusting all relevant parameters is made easy by the clear display with graphic capability and multiple line plain text user prompts.

#### Prepared for solar

In combination with a solar thermal system, current solar data is also shown on the display. The collector and cylinder temperature are included in this data, as are the operating hours of the solar thermal system.

#### Take advantage of these benefits

- Fully automatic wood pellet boiler with a rated heating output range of 2.4 to 12 kW
- Efficiency of up to 95.3 % for excellent utilisation of wood-based energy
- Innovative combustion technology for lowest dust emission levels – meets the first German Immissions Ordinance (1st BImSchV), level 2.
- Flexible, space saving installation – may be sited in a corner
- Can be located anywhere as its operation does not depend on ambient air
- Low power consumption due to automatic ignition with ceramic heating element
- Ecotronic control unit with plain text user prompts and automatic function monitoring, plus solar and buffer cylinder charging control
- Automatic ash removal from the combustion chamber through a stainless steel finned grate ensures highly reliable operation and long cleaning intervals
- Ash box requires emptying only once or twice a year
- High operational reliability provided by rotary lock valve, for 100 percent burn-back protection
- Flexible fuel feed, e.g. pellet vacuum system or manual charging with pellet sack
- Extensive accessories for pellet supply and storage
- Convenient operation via Viessmann app and smartphone

For specification, see page 26

## Pellet boiler

### Vitoligno 300-C 18 to 48 kW



Wood pellets are the most tightly compressed form of wood-based energy.



Ecotronic control unit with multiple line, illuminated display



Convenient operation via Viessmann app and smartphone

#### Compact, fully automatic pellet boiler for new and existing installations

The Vitoligno 300-C is a fully automatic pellet boiler with output range from 6 to 48 kW. It offers versatile and flexible supply system options for almost any application. It stands out on account of its compact design which is ideal for limited room heights. A suction turbine and pellet hopper sufficient for one-day-operation are already integrated.

#### Convenient automatic functions

The pellet boiler is automated and convenient to use. The automated features include ignition, heat exchanger cleaning, self-cleaning finned grate and fully automatic compaction of ash inside the ash box. The mobile ash box only needs emptying once or twice a year.

#### Intelligent Ecotronic control unit

Operating the Vitoligno 300-C is easy with the weather-compensated digital Ecotronic control unit. It regulates

- up to three heating circuits with mixer,
- two heating circuits with mixer and DHW heating, or
- one heating circuit with mixer, a solar circuit and DHW heating;
- an additional fourth heating circuit with mixer can be connected via the KM-BUS.

The boiler with pellet supply, the heating circuits and the cylinder temperature can all be controlled intuitively. Adjusting all relevant parameters is made easy by the clear display with graphic capability and multiple line plain text user prompts. In addition, an integrated assistant facilitates commissioning of the Vitoligno 300-C. Using the help function, the installer is guided through the commissioning process by the control unit.

#### Efficient and environmentally responsible

The Vitoligno 300-C has an efficiency of up to 95 percent when converting wood pellets into heat. Modulation of 1:3 leads to low consumption and clean combustion under partial load conditions. A ceramic ignition unit consumes little power, whilst innovative combustion technology keeps dust values low. This boiler meets the first German Immissions Ordinance (1st BImSchV), level 2.

#### Matching accessories

The controlled return temperature raising facility ensures the perfect hydraulic connection of the Vitoligno 300-C. Delivered as a fully assembled unit, the return temperature raising facility can be connected to the boiler within a very short time.



#### Vitoligno 300-C

- 1 Ecotronic control unit with user prompts
- 2 Automatic heat exchanger cleaning
- 3 Integral suction turbine
- 4 Variable speed flue gas fan for modulating operation
- 5 Pellet hopper
- 6 Rotary lock valve for 100 % burn-back protection
- 7 Combustion chamber made from high temperature-resistant ceramics
- 8 Self-cleaning finned grate made from stainless steel
- 9 Automatic ash removal with mobile ash box



Vitoligno 300-C (18 to 48 kW) with a pellet hopper (left)

For pellet stores, a modular 4-/8-way wand changeover is available. It is regulated by the Ecotronic and ensures an even discharge of pellets, by changing the wands over automatically. The wand system can be routed flexibly and is suitable for the most diverse spaces, making optimum use of the pellet store.

For manual charging from pellet sacks, the pellet box can be positioned right next to the Vitotigno 300-C or, if preferred, anywhere inside the room. A 260 kilogram load is sufficient for up to ten days.

#### Take advantage of these benefits

- Fully automatic, convenient wood pellet boiler with a rated heating output range of 6 to 48 kW
- Pellet boiler for limited room heights
- Adjacent pellet hopper for one week's operation
- Efficiency of up to 95.1 % for excellent utilisation of wood-based energy
- Innovative combustion technology for lowest dust emission levels – meets the first German Immissions Ordinance (1st BImSchV), level 2
- Modulation 1:3
- Self-cleaning finned grate made from stainless steel
- Ecotronic control unit with user prompts and plain text display
- High operational reliability provided by rotary lock valve, for 100 percent burn-back protection
- Power saving, automatic ignition with ceramic heating element
- Automatic ash removal via mobile ash box, which only needs to be emptied once or twice a year
- Matching and easy-to-fit accessories for pellet supply and storage
- Convenient operation via Viessmann app and smartphone

For specification, see page 26

## Pellet boiler

### Vitoligno 300-C 60 to 101 kW



Wood pellets are the most tightly compressed form of wood-based energy.



Vitotrol 350-C – with 5" colour touchscreen as remote control, control loop extension and cascade controller



Convenient operation via Viessmann app and smartphone

#### Convenient central heating unit for automatic charging with wood pellets

The Vitoligno 300-C biomass boiler offers a multitude of automatic functions that make for particularly convenient operation. These functions include an efficient ignition system with low power consumption, as well as fully automatic ash removal from the grate and heat exchanger. Because of the arrangement of the heat exchanger, very little ash is deposited, making long cleaning intervals possible. The turbulators provide a permanently efficient heat transfer and lower dust emissions. Emptying the large sealable and mobile ash box is an almost entirely dust-free process.

#### Efficient and environmentally responsible

The Vitoligno 300-C has an efficiency of up to 96 percent when converting wood pellets into heat. With its weather-compensated control unit and a modulation range of 1:3, the biomass boiler adapts its output precisely to the current heat demand. This means that the Vitoligno 300-C has impressively low fuel consumption.

Variable combustion means high efficiency and low emissions, with lambda supported primary and secondary air control. The secondary combustion chamber, developed using CFD simulation, facilitates an optimum mixing of the combustion gases

with secondary air. This is due to the fact that both the constriction of the diameter and the twisted firebricks of the flame duct facilitate a turbulent mixing of the combustion gases for a complete burnout. The extremely heat-resistant silicon carbide stones also provide a hot combustion zone. This leads to particularly low emissions, meeting the first German Immissions Ordinance (1st BImSchV), level 2.

#### Flexible fuel feed

Depending on requirements and application, pellets can be charged into the boiler via either a flexible screw conveyor or a vacuum system. Filling the pellet hopper is particularly quiet, thanks to innovative sound-optimisation.

To save space, the fuel supply can be mounted on either the right or the left (from 80 kW). Up to 70 kW, with fuel supply from the back. This allows flexible and space saving positioning with single sided wall installation to the right. No maintenance or inspection work needs to be carried out from this side.

#### Innovative and versatile control

The integral Ecotronic control unit regulates the following:

- up to three heating circuits with mixer,
- two heating circuits with mixer and DHW heating,
- one heating circuit with mixer, a solar circuit and DHW heating,
- a fourth heating circuit with mixer for connection via KM-BUS.



#### Vitoligno 300-C, 80 to 101 kW

- 1 Integral Ecotronic control unit
- 2 Fully automated heat exchanger cleaning
- 3 Vertical heat exchanger with turbulators
- 4 High temperature-resistant combustion chamber with variable combustion and regulated primary and secondary air supply
- 5 Sliding grate
- 6 Fully automatic ash removal from grate and heat exchanger
- 7 Mobile ash box
- 8 Large capacity pellet hopper





Vitoligno 300-C  
60 to 70 kW

Vitoligno 300-C  
80 to 101 kW

In combination with the Vitotrol 350-C touchscreen (option), the boiler can also be controlled from the living space. The system can be extended to include up to 24 control loops using control modules. These can be used for heating circuits, DHW heating or in conjunction with a district heating supply line. The Vitotrol 350-C can also be used as a cascade controller for up to four wood boilers.

#### Matching accessories

The Vitotigno 300-C range of accessories includes extensive storage and supply systems for wood pellets. For pellet stores without a sloping floor, a modular 4-/8-way wand changeover is available. Suction wands, evenly distributed in the pellet store, transport the wood pellets from the pellet store to the pellet boiler. The routing of the wand system is flexible and suitable for various room formats (e.g. L-shaped, very elongated spaces or even split stores). As the sloping floor is no longer required, usable space is increased by up to 1/3 – this ensures optimum use of the pellet store.

#### Take advantage of these benefits

- Fully automatic biomass boiler with an efficiency of up to 96 %
- Heating output: 60 to 101 kW
- Low fuel consumption through high efficiency, modulating operation and weather-compensated control
- Ecotronic control unit with commissioning assistant for up to four heating circuits
- High operational reliability through self-cleaning grate
- Integrated, controlled return temperature raising facility (up to 70 kW)
- High operating convenience and extended service intervals thanks to automatic cleaning and removal of ash from the heat exchanger and grate
- Fuel supply via either a vacuum system or a flexible screw conveyor
- The pellet hopper can be filled during operation
- Sound-optimised pellet hopper for low-noise fuel delivery
- Low power consumption due to automatic ignition with ignition element
- Broadband lambda probe for optimised combustion control
- Low dust emission levels meet the first German Immissions Ordinance (1st BImSchV), level 2
- Extensive accessories for pellet supply and storage
- Cascading of up to 4 wood boilers with the Vitotrol 350-C (option)
- Convenient operation via Viessmann app and smartphone

For specification, see page 27

## Wood gasification boiler

## Vitoligno 200-S 20 to 50 kW



reddot design award

The Vitotrol 350-C remote control unit with touchscreen won the prestigious red dot design award from the Design Zentrum North Rhine-Westphalia in 2014.



Convenient operation via Viessmann app and smartphone

The Vitoligno 200-S wood gasification boiler for logs is a good alternative to an oil or gas heating system, as wood is affordable and CO<sub>2</sub> neutral.

The Vitoligno 200-S is a high quality wood gasification boiler with output from 20 to 50 kW. In the output range 30 to 50 kW it operates in modulating mode, variably adjusting its output to the respective heat demand. The large stainless steel charging hopper can hold logs up to 50 cm long.

### Heat-up in a matter of minutes

The heat-up process is complete after just a few minutes. A reduced oxygen feed to the hopper ensures that the logs carbonise rather than burn. The ignitable wood gas then burns cleanly and at high temperatures under supply of secondary air. Secondary wood gas combustion enables the reliable control of full and partial loads.

To ignite the fuel, an automatic ignition device is available as an optional extra. The control unit also enables programming of the required ignition time.

### Digital control

The boiler control unit, with user prompts, makes the operation of the Vitoligno 200-S particularly easy. Up to three heating circuits can be controlled with the standard version. Buffer charging management is part of the control system. This ensures the best possible utilisation of the buffer energy whilst optimising the heat transfer by the Vitoligno 200-S. Re-use of residual heat in the burnout provides savings on fuel costs of up to 9 percent.

### Easy cleaning

The Vitoligno 200-S heat exchanger is quick and easy to clean using a lever mechanism. Thorough carbonisation ensures that very few residues remain. This means that ash only needs to be removed every two weeks or so, even during the heating season.

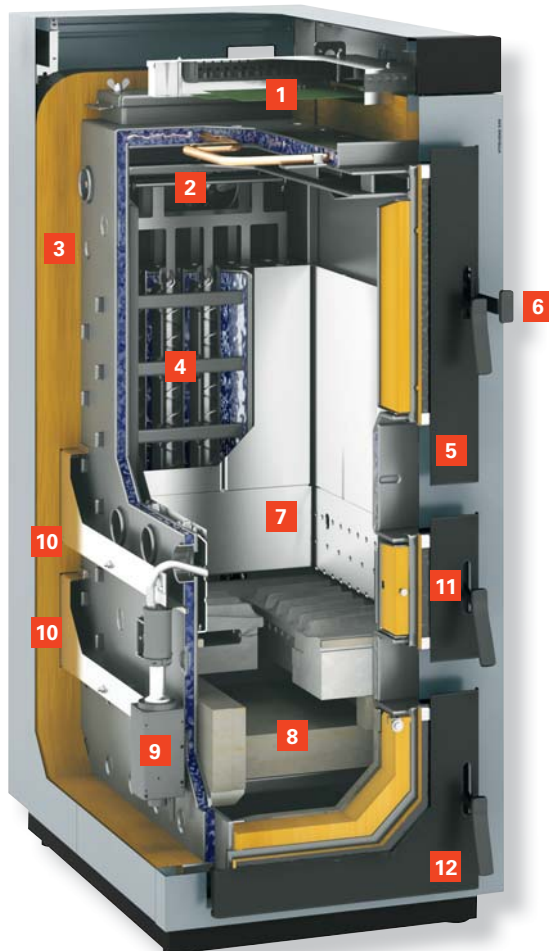

### Vitoligno 200-S

- 1 Fully wired control unit with user prompts
- 2 Variable speed flue gas fan for modulating operation
- 3 100 mm thick thermal insulation
- 4 Heating surfaces
- 5 Large hopper door
- 6 Convenient cleaning of heating surfaces
- 7 Large hopper
- 8 Combustion chamber made from durable fireclay
- 9 Automatic ignition (option)
- 10 Infinitely variable primary and secondary air
- 11 Ignition door
- 12 Ash door



Logs up to 50 cm long are no problem for the high quality Vitoligno 200-S wood gasification boiler.

### Remote control unit with touchscreen

With the Vitotrol 350-C touchscreen, the wood gasification boiler can also be controlled from the living space. With the 5" display in 16:9 format, operation could hardly be easier. The Vitotrol 350-C wall mounted device enables remote control of the boiler with all the necessary setting options, displaying all relevant information on the boiler and the heating water buffer cylinder.

The Vitotrol 350-C is more than just a remote control unit. It can also expand the system to include up to 20 additional control extensions (heating circuit, DHW heating) in a single device.

### Take advantage of these benefits

- High performance wood gasification boiler, 20 to 40 kW: for logs up to 50 cm long
- Efficiency up to 93.2 %
- Short heat-up procedure for heat availability in a few minutes
- Modulating operation (30 to 50 kW) for continuous matching to the actual heat demand
- Large stainless steel hopper for long logs and prolonged combustion
- Effective carbonisation gas removal for low smoke recharging after full burnout
- Particularly clean combustion
- Ecotronic boiler control unit with user prompts, for controlling up to three heating circuits with mixer, commissioning assistant and integral buffer cylinder management system
- Easy lever-operated mechanical cleaning of the heating surfaces and long cleaning intervals
- High operating convenience resulting from automatic ignition (option)
- Vitotrol 350-C remote control unit (option)
- Convenient operation via Viessmann app and smartphone

For specification, see page 28

## Vitoligno 150-S 17 to 45 kW



Ecotronic 100 control unit with backlit display for simple and intuitive operation

The Vitoligno 150-S is a compact, attractively priced log gasification boiler, which is suitable for both mono mode and dual mode operation (as an addition to oil or gas heating systems).

The Vitoligno 150-S is a very attractively priced log gasification boiler with rated heating output from 17 to 45 kW. It is suitable for dual mode as well as mono mode operation in detached houses and apartment buildings.

Viessmann provides a comprehensive product range for heating with wood. Choosing a Vitoligno 150-S wood boiler is both economical and environmentally responsible. Significant independence from oil and gas, as well as cost savings through careful energy consumption, are further notable benefits. Furthermore, an investment such as modernising a heating system can also qualify for attractive subsidy programmes.

### Ideal addition to oil or gas heating systems

This compact log boiler is also an excellent heating addition to an existing oil or gas heating system. In dual mode, it covers the base demand for heating energy and DHW. The oil/gas boiler only needs to come into play to cover peak loads when temperatures fall to extremely low levels.

The Vitoligno 150-S operates in modulating mode and adapts continuously to the current heat demand. The combustion controller, with Lambda probe and flue gas temperature sensor, captures the oxygen content and the temperature of the flue gases. It ensures low emissions and high efficiency of up to 93.1 percent. The Vitoligno 150-S is therefore able to convert logs into usable heat in a highly economical manner.

### Heat-up in a matter of minutes

The heat-up procedure is accelerated by a heat-up flap and it takes less than three minutes for the logs to be ignited and burn.

### Heating with convenience: Vitoligno 150-S

The large hopper allows for long recharging intervals and burnout times. The Vitoligno 150-S can be charged with logs up to 56 cm long. Carbonisation gas removal ensures low smoke recharging of logs. Heating surfaces are easily cleaned from the side using a lever. Due to the gasification technology and combustion control with Lambda probe, the Vitoligno 150-S achieves a high level of efficiency and clean, efficient combustion with very low dust levels. Door opening on either side ensures optimum use of space and allows installation in corners.

### Ecotronic 100 digital control unit

The Ecotronic 100 control unit is remarkably simple and intuitive. The backlit display shows all information as symbols. The heat-up condition of the heating water buffer cylinder is also displayed as a graphic on the screen, in the form of a progress bar.

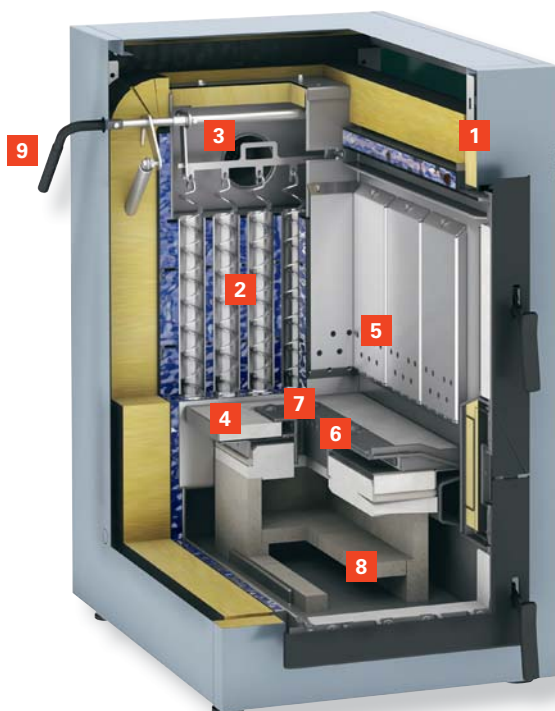

### Vitoligno 150-S

- 1 Ecotronic 100 control unit with Lambda probe
- 2 Heat exchanger
- 3 Variable speed flue gas fan
- 4 Special refractory concrete combustion chamber
- 5 Hopper lining with primary air outlet
- 6 Secondary air outlet in the combustion chamber
- 7 Steel burner nozzle
- 8 Special refractory concrete burnout channel
- 9 Lever mechanism for semi-automatic heat exchanger cleaning



#### Take advantage of these benefits

- Wood gasification boiler with 17, 23, 30, 34.9 and 45 kW
- Efficiency: up to 93.1 %
- Carbonisation gas removal for low-smoke recharging
- Output modulation ensures heat generation is matched to the current heat demand
- Simple and intuitive control unit operation with backlit display
- Software update function via SD card
- Optimum combustion through Lambda probe control
- Low dust emissions through clean and efficient combustion (compliant with 1st BImSchV, stage 2, Bafa subsidy)
- Large hopper for logs up to 56 cm long allows for long recharging intervals and combustion times
- Variable speed flue gas fan with function monitoring for highest possible operational reliability
- Lever mechanism for semi-automatic cleaning of the heat exchanger
- Easily accessible service apertures for convenient ash removal and cleaning from the front
- Door opening on either side ensures optimum use of space and allows installation in corners
- Low power consumption saves costs

For specification, see page 28

## Log boiler

### Vitoligno 250-S 40 to 170 kW



The Vitotrol 350-C remote control unit with touchscreen won the prestigious red dot design award from the Design Zentrum North Rhine-Westphalia in 2014.



Convenient operation via Viessmann app and smartphone

The Vitoligno 250-S was developed specifically for the combustion of logs and represents the very latest in combustion technology.

#### Integral heat management

The Vitoligno 250-S was developed specifically for the combustion of logs and represents state of the art combustion technology. This log boiler has already stood the test in thousands of applications. Charging from the top means easy handling, control via the Lambda probe guarantees low emissions and the integral heat management system ensures maximum convenience.

#### Clean and efficient combustion

The microprocessor controller records all data relevant for operation and regulates heat distribution. As a result, the boiler system is continuously monitored in all operating phases, from heat-up and operation under load, right through to burnout, and is held within its optimum operating range by motorised air dampers. This guarantees clean and efficient combustion.

#### Applications

Extension kits (accessories) can be used to incorporate heat consumers or DHW cylinders into the control system. The Vitoligno 250-S is suitable for use in detached houses, apartment buildings, agricultural applications or commercial operations.

#### Large hopper

Thanks to its large charging chute, the Vitoligno 250-S offers great convenience during heating, whether with logs, wood briquettes or wood remnants, either in pieces or loose. Log boilers with a rated heating output range of 40 to 75 kW can be charged with logs of 50 cm in length. In the 85 to 170 kW range the hopper width increases to 1080 mm, allowing convenient charging even with logs of 1 m in length.

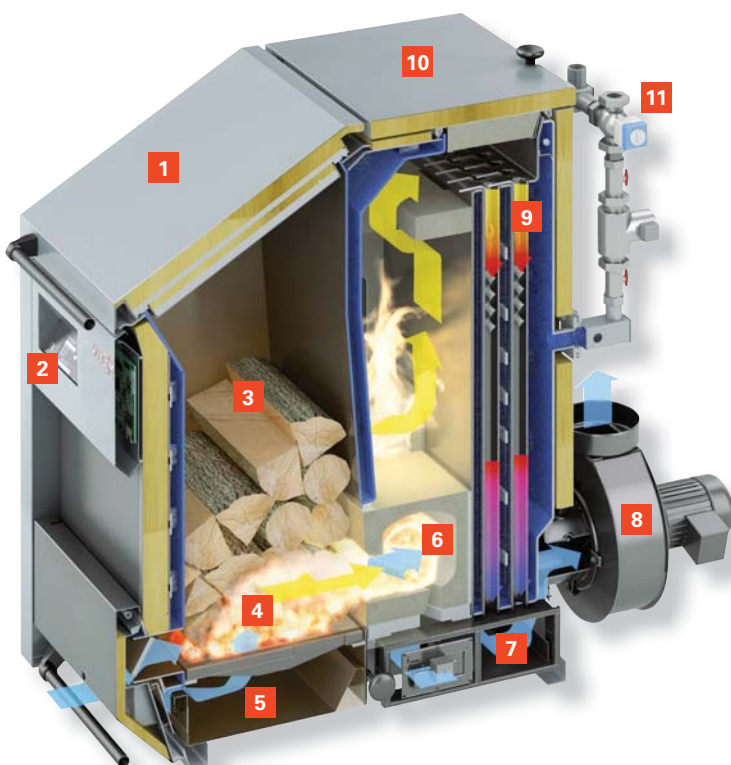

#### Vitoligno 250-S

- 1 Easily accessible hopper door for charging the log boiler from the top
- 2 Weather-compensated control
- 3 Hopper tapering downwards for reliable fuel recharging
- 4 Degassing zones with cast stainless steel grate and fireclay bed
- 5 Large, easily accessible ash pan for the grate ash
- 6 Combustion chamber made from high temperature-resistant refractory concrete
- 7 Ash box below the heat exchanger
- 8 Flue gas fan with Lambda probe and flue gas temperature sensor
- 9 Vertical tubular heat exchanger
- 10 Top cleaning cover
- 11 Return temperature raising facility included in the standard delivery (boiler assembly) with boiler circuit pump, boiler control valve, flow and return sensor



Vitotigno 250-S  
Log boiler for 50 cm logs, 40 to 75 kW

### Remote control unit with touchscreen

With the Vitotrol 350-C touchscreen, the wood gasification boiler can also be controlled from the living space. With the 5" display in 16:9 format, operation could hardly be easier. The Vitotrol 350-C wall mounted device enables remote control of the boiler with all the necessary setting options, displaying all relevant information on the boiler and the heating water buffer cylinder.

The Vitotrol 350-C is more than just a remote control unit. It can also expand the system to include up to 20 additional control extensions (heating circuit, DHW heating) in a single device.

### Take advantage of these benefits

- Log boiler from 40 to 170 kW for logs 50 cm and 1 m in length, with high operating convenience thanks to charging from the top
- For the following fuels: logs, wood briquettes and wood remnants as shavings or in pieces
- Large hopper capacity (185 to 500 litres)
- Efficiency up to 93.2 %
- Control with Lambda probe ensures very low emissions
- Fully wired
- Constantly regulating air dampers with heat-up and burnout optimisation
- Accurate temperature stratification inside the heating water buffer cylinder by means of a buffer cylinder control valve – no possible disturbance of the buffer stratification through the return
- A controlled return temperature raising facility is fully fitted
- Robust, resilient display integrated into the boiler
- Straightforward user prompts with context-sensitive help function
- Integral buffer charging management
- Not sensitive to foreign bodies (nails, screws, etc.)
- Vitotrol 350-C remote control unit (option)
- Convenient operation via Viessmann app and smartphone

For specification, see page 29

## Wood boiler

### Vitoligno 250-F 35 to 100 kW



Vitoligno 250-F for fuel flexibility

The Vitoligno 250-F is suitable for manual charging with logs, wood briquettes, wood remnants with shavings and wood remnant pieces, as well as for automatic charging with wood pellets and woodchips.

The Vitoligno 250-F can convert many forms of wood fuel into heating energy. If the wood boiler is equipped with automatic charging, the fuel is automatically ignited by an ignition fan. Combined with a DHW cylinder, this permits perfect low-load control (DHW mode in summer).

#### Self-cleaning heat exchanger surfaces

The vertical heat exchanger surfaces are permanently cleaned by motorised coil springs. The drive mechanism is situated low down in the protected, cool gas flow. The springs can be removed easily for annual cleaning by the flue gas inspector.

The high efficiency of the Vitoligno 250-F results from the long burnout path, optimum heat transfer, self-cleaning boiler passes and the utilisation of residual heat in the ash. In standard mode, the ash is automatically removed from the main combustion chamber into the front combustion chamber, where it remains until it has ceased to glow.

#### Large hopper

The large hopper above the combustion chamber allows for convenient operation with logs. A simple push of a button is enough to change over to log combustion (patented air damper function).

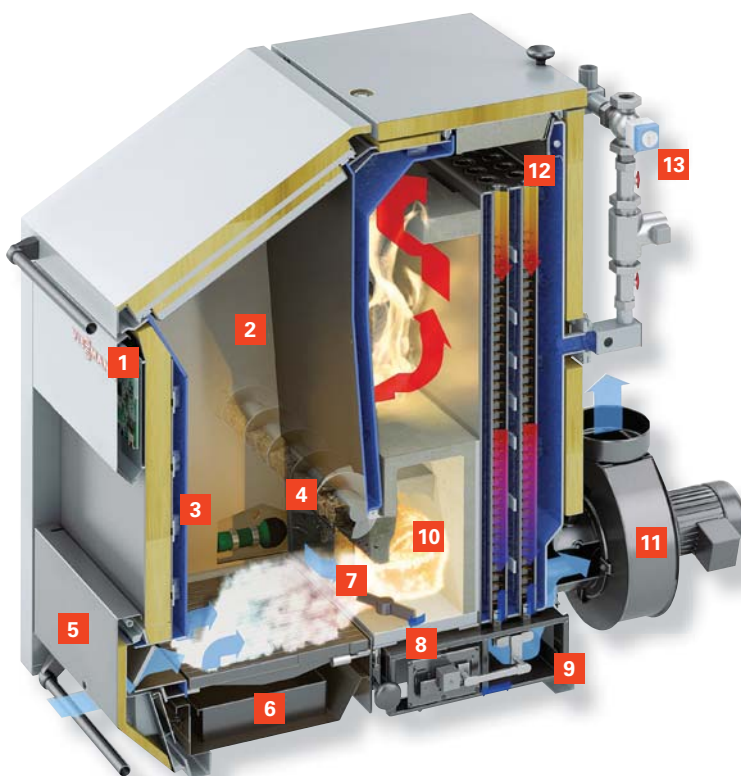

#### Vitoligno 250-F

- 1 Weather-compensated control
- 2 Front combustion chamber charged from the top
- 3 Automatic ignition fan
- 4 Feed screw conveyor and degassing grate with primary air
- 5 Combustion chamber door with primary air damper
- 6 Large ash chamber with utilisation of residual heat
- 7 Combustion chamber made from heat-resistant refractory concrete
- 8 Automatic ash removal from the combustion chamber
- 9 Drive for automatic ash removal and cleaning
- 10 Secondary combustion chamber (secondary air via combustion chamber door)
- 11 Variable speed flue gas fan with Lambda probe and temperature sensor
- 12 Tubular heat exchanger with automatic cleaning
- 13 Return temperature raising facility included in the standard delivery (boiler assembly) with boiler circuit pump, boiler control valve, flow and return sensors





Vitoligno 250-F with automatic charging system

#### Take advantage of these benefits

- Wood boiler for manual and automatic charging
- Highly convenient operation – charging with logs from the top
- Automatic charging with wood pellets or woodchips
- Boiler efficiency: up to 94,2 %
- Control with Lambda probe ensures very low emissions
- Fully wired
- Accurate temperature stratification inside the heating water buffer cylinder by means of a buffer cylinder control valve – no possible disturbance of the buffer stratification through the return (option)
- A controlled return temperature raising facility is fully fitted
- Re-use of residual heat, with 8 % higher efficiency
- Automatic ignition via hot air fan
- Automatic heat exchanger cleaning
- Automatic ash removal into a 20 litre ash box (option)

For specification, see page 29



Vitoligno 300-C

<b>Rated heating output range</b>	kW	2.4 – 8	2.4 – 12
<b>Dimensions</b>			
Length	mm	770	770
Width	mm	850	850
Height	mm	1250	1250
<b>Weight</b>	kg	310	310
<b>Flue gas connection ø</b>	mm	100	100
<b>Energy efficiency class</b>		A+	A+



Vitoligno 300-C

<b>Rated heating output range</b>	kW	6 – 18	8 – 24	11 – 32	13 – 40	18 – 48
<b>Dimensions with pellet hopper</b>						
Length (depth)	mm	1127	1127	1224	1224	1224
Width	mm	1175	1175	1332	1332	1332
Height	mm	1367	1367	1539	1539	1539
<b>Dimensions with connection unit for the flexible screw conveyor</b>						
Length (depth)	mm	1127	1127	1224	1224	1224
Width	mm	1142	1142	1244	1244	1244
Height	mm	1367	1367	1539	1539	1539
<b>Weight with pellet hopper</b>	kg	510	510	650	650	650
<b>Weight with flexible screw conveyor</b>	kg	492	492	615	615	615
<b>Boiler water content</b>	l	100	100	180	180	180
<b>Pellet hopper capacity</b>	kg	40	40	65	65	65
<b>Flue gas connection ø</b>	mm	130	130	150	150	150
<b>Energy efficiency class</b>		A+	A+	A+	A+	A+



Vitoligno 300-C

<b>Rated heating output range</b>	kW	18 – 60	21 – 70
<b>Dimensions with pellet hopper</b>			
Length (depth)	mm	1923	1923
Width	mm	1156	1156
Height	mm	1695	1695
<b>Dimensions with connection unit for the flexible screw conveyor</b>			
Length (depth)	mm	1923	1923
Width	mm	1156	1156
Height	mm	1654	1654
<b>Weight with pellet hopper</b>	kg	1050	1050
<b>Weight with flexible screw conveyor</b>	kg	1014	1014
<b>Boiler water content</b>	l	210	210
<b>Pellet hopper capacity</b>	kg	130	130
<b>Flue gas connection <math>\varnothing</math></b>	mm	150	150
<b>Energy efficiency class</b>		A+	A+



Vitoligno 300-C

<b>Rated heating output range</b>	kW	24 – 80	30 – 99	30 – 101
<b>Dimensions with pellet hopper</b>				
Length (depth)	mm	1717	1717	1717
Width	mm	1758	1758	1758
Height	mm	1895	1895	1895
<b>Dimensions incl. connection unit for the flexible screw conveyor</b>				
Length (depth)	mm	1717	1717	1717
Width	mm	1758	1758	1758
Height	mm	1856	1856	1856
<b>Weight with pellet hopper</b>	kg	1472	1472	1472
<b>Weight with flexible screw conveyor</b>	kg	1430	1430	1430
<b>Boiler water content</b>	l	240	240	240
<b>Pellet hopper capacity</b>	kg	200	200	200
<b>Flue gas connection <math>\varnothing</math></b>	mm	200	200	200

## Specification

### Vitoligno 200-S Vitoligno 100-S



#### Vitoligno 200-S

<b>Rated heating output</b>	kW	20	30	40	50
<b>Dimensions</b>					
Length	mm	1165	1165	1165	1165
Width	mm	714	714	714	714
Height	mm	1587	1587	1797	1797
<b>Weight</b>	kg	770	770	865	865
<b>Flue gas connection Ø</b>	mm	150	150	150	150
<b>Fuel hopper capacity</b>	l	169	169	211	211
<b>Energy efficiency class</b>		A+	A+	A+	A+



#### Vitoligno 150-S

<b>Rated heating output</b>	kW	17.0	23.0	30.0	34.9*	45.0*
<b>Dimensions</b>						
Length	mm	1373	1373	1373	1373	1373
Width	mm	700	700	700	800	800
Height	mm	1230	1230	1390	1600	1600
<b>Weight</b>	kg	502	502	595	719	719
<b>Flue gas connection Ø</b>	mm	130	130	150	150	150
<b>Fuel hopper capacity</b>	l	79	79	120	180	180
<b>Energy efficiency class</b>		A+	A+	A+	A+	A+

\* available from 04/2017

## Vitoligno 250-S Vitoligno 250-F



### Vitoligno 250-S

For 50 cm logs

<b>Rated heating output</b>	kW	40	50	60	75
<b>Hopper</b>					
Width	mm	550	550	550	550
Contents	l	185	185	255	255
<b>Dimensions</b>					
Length	mm	958	958	1163	1163
Width	mm	795	795	795	795
Height	mm	1433	1433	1490	1490
<b>Weight</b>	kg	750	760	920	935
<b>Flue gas connection Ø</b>	mm	200	200	200	200
<b>Energy efficiency class</b>		A+	A+	A+	-



### Vitoligno 250-S

For 1 m logs

<b>Rated heating output</b>	kW	85	100	120	170
<b>Hopper</b>					
Width	mm	1080	1080	1080	1080
Contents	l	375	375	500	500
<b>Dimensions</b>					
Length	mm	1018	1018	1353	1353
Width	mm	1324	1324	1324	1324
Height	mm	1433	1433	1490	1490
<b>Weight</b>	kg	1300	1320	1680	1720
<b>Flue gas connection Ø</b>	mm	200	200	250	250



### Vitoligno 250-F

<b>Rated heating output</b>				
Operation with logs	kW	49	75	100
<b>Rated heating output</b>				
Operation with woodchips/pellets	kW	49	68	85
<b>Hopper</b>				
Width	mm	550	550	550
Contents	l	185	255	255
<b>Dimensions</b>				
Length	mm	958	1163	1313
Width	mm	795	795	795
Height	mm	1430	1490	1490
<b>Weight</b>	kg	760	935	1065
<b>Flue outlet</b>	mm	200	200	200
<b>Energy efficiency class</b>		A+	-	-

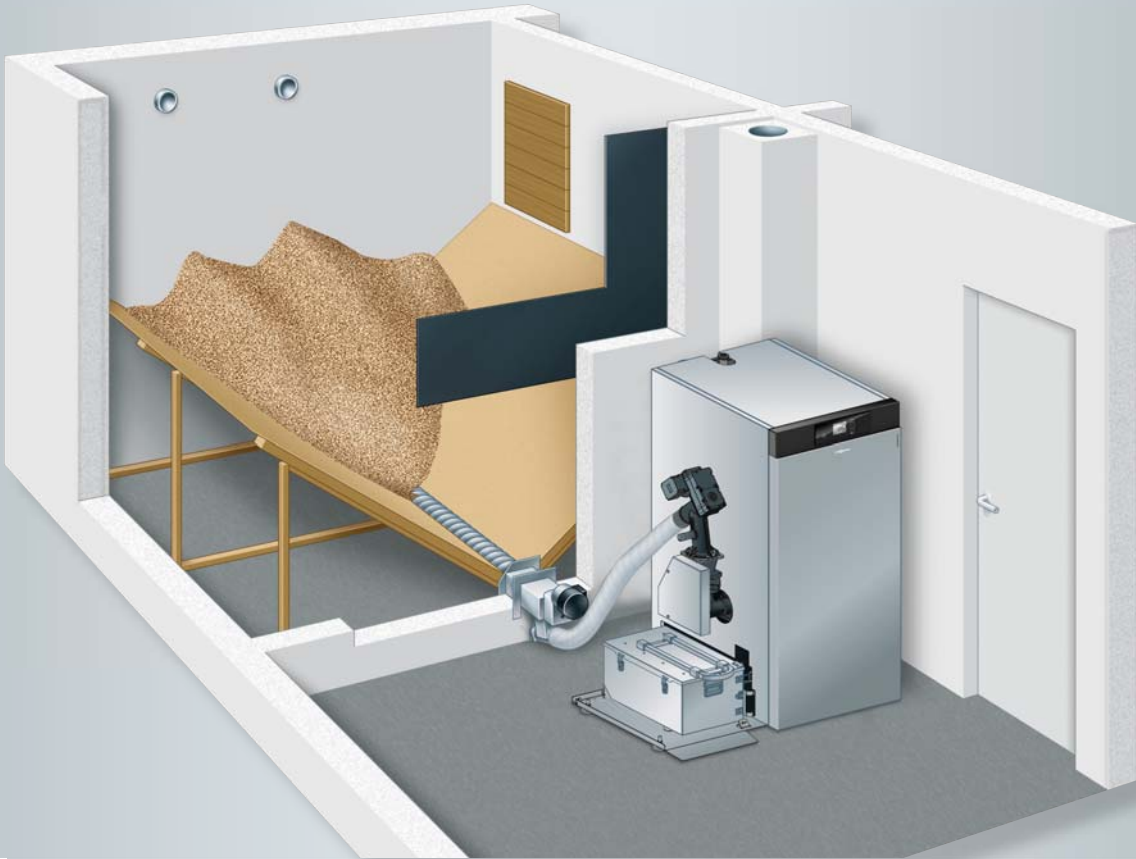

## System technology ensures reliable and economical operation

The convenient controls and perfectly matched Viessmann system components offer maximum reliability, flexibility and efficiency.

"The whole is greater than the sum of its parts". In accordance with this philosophy, Viessmann supplies more than high quality, reliable and effective heating components. In fact, all products are part of a matching total concept, where all components complement one another. After all, only perfect interaction between all system components can draw out the maximum potential of our innovative leading technology.

Viessmann system technology incorporates everything which constitutes a reliable heating system that is economical to run: powerful Vitocell DHW cylinders for high DHW convenience, as well as high quality solar thermal systems for cost effective DHW heating and central heating backup.

Naturally this also includes the complete range of accessories for pellet storage with discharge systems for every application area.

**System components**

Extensive accessories for operating wood heating systems. Fuel storage with discharge systems for every application.



**Operating convenience**

Clear, convenient and intelligent: The boiler and heating circuit control units offer perfect functionality for fast and precise control of any heating system. The intelligent control extension also enables the integration of other control loops as well as boilers.



**Solar thermal and photovoltaics**

Energy from the sun is free: Solar thermal systems deliver hot water for DHW heating and central heating backup. By installing a photovoltaic system, everyone can become their own electricity supplier and use the power they have generated on site.



**DHW cylinders**

DHW convenience for every aspiration – Vitocell DHW cylinders are convenient solutions for supplying a household with hot water – the perfect complement to any new wood boiler.



Scan the QR code to receive further information about Vitocell

**System accessories**

Radiators, expansion vessels, pipework systems, pumps, filters and valves – Vitoset offers the complete range of accessories for your Viessmann heating system.



Scan the QR code to discover more about the Viessmann radiator range



Pellet silo

## Integrated pellet systems

### Pellet storage with discharge systems for every application



Pellet box measuring 1230 x 600 x 770 mm (length x width x height)

For lasting and reliable operation, the pellet boiler, discharge system and pellet store must form an integrated unit.

Pellets can be supplied by means of tankers and blown into the pellet store.

A hose length of 30 metres should not be exceeded when filling the pellet store. If longer hose lengths are to be expected, please consult with your pellet supplier to find out more about their technical options.

The access route must be suitable for tankers. Generally a road width of at least three metres and an overhead clearance of at least four metres is required.

If possible, the pellet store should adjoin an outside wall. There should be a 230 volt power supply for the pellet supplier's vacuum fan and an electrical isolator for the pellet boiler.

#### **Pellet box – the small pellet storage solution of choice**

The pellet box is useful if there is not enough space for a pellet store. It provides an affordable and simple way to store pellets.



### Storage and supply to the pellet boiler via a vacuum system

The vacuum system is deployed wherever the pellet store does not directly adjoin the room where the pellet boiler is installed. With the vacuum system, wood pellets can be transported over a distance of up to 25 metres. The flexible positioning of the vacuum supply system enables installations even in tight spaces.

The vacuum system can also be adapted for use with a room discharge screw conveyor, pellet silo or modular 4-/8-way wand changeover with freely positionable suction wands.

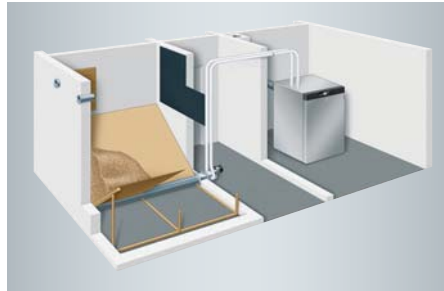

Pellet store and supply to the pellet boiler via a vacuum system



Pellet silo (fabric container) and supply to the pellet boiler via a vacuum system

### Storage and supply to the pellet boiler via flexible screw conveyor

If the pellet store or the pellet silo is situated immediately adjacent to the boiler room, the pellet boiler can be supplied via a flexible screw conveyor directly to the rotary lock valve. Using this system means there is no need for a pellet hopper at the boiler. The drive unit for the flexible screw conveyor is installed directly at the boiler on the rotary lock valve.



Pellet store and supply to the pellet boiler via flexible screw conveyor



Pellet silo (fabric container) and supply to the pellet boiler via flexible screw conveyor

### Pellet box for manual charging from pellet sacks

For manual charging from pellet sacks, the pellet box can be positioned right next to the Vitotigno 300-C or, if preferred, anywhere inside the room. A 260 kilogram load is sufficient for up to ten days.



Pellet box – the flexible and compact pellet store

## Control technology – heating economically by design

The integral control unit enables operation of the entire system with up to four heating circuits for DHW heating and central heating backup.



Ecotronic control unit with multiple line, backlit screen and plain text display, also offering simplified commissioning (commissioning assistant) thanks to the Plug and Work function

### Regulates up to four heating circuits

The weather-compensated Ecotronic digital boiler and heating circuit control unit is a decentralised microprocessor system. The Ecotronic regulates the following:

- up to three heating circuits with mixer
- two heating circuits with mixer and DHW heating
- one heating circuit with mixer, a solar circuit and DHW heating
- a fourth heating circuit with mixer for connection via KM-BUS

In combination with the Vitotrol 350-C digital control unit (option), the boiler can also be controlled from the living space.

With the 5-inch colour touchscreen in 16:9 format, operation could hardly be easier. The Vitotrol 350-C enables remote control of the boiler with all relevant adjustment options and displays all the necessary information about the boiler and heating water buffer cylinder.

### Heat management for log gasification boiler (ECO function)

- During burnout, any heat not required for heating purposes is channelled into the heating water buffer cylinder with precise temperature stratification.
- After burnout, the residual heat in the boiler water is fully utilised.
- Only then is heat supplied to the heating water buffer cylinder. The proven control concept for heating convenience discharges the heating water buffer cylinder with precise temperature stratification.

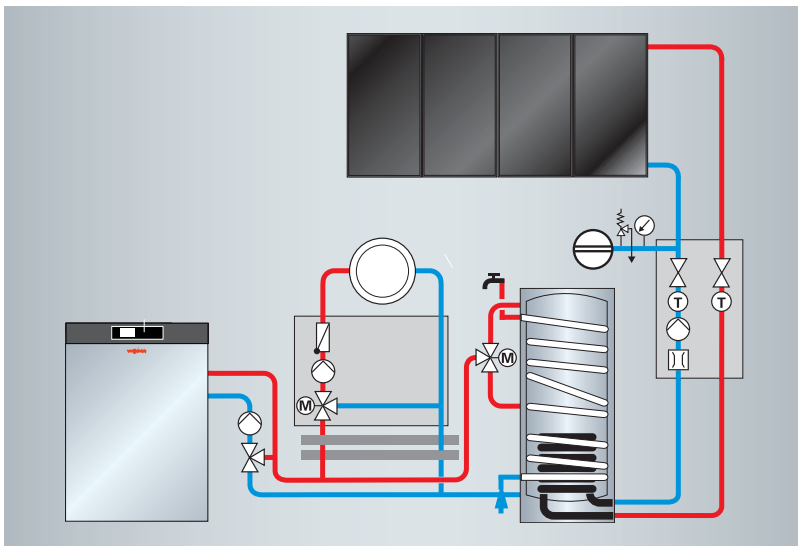

Wood boiler with one heating circuit, DHW heating and solar thermal system

## Vitotrol 350-C – the intelligent cascade control unit for biomass boilers

### Clear, convenient and intelligent

In combination with the Vitotrol 350-C digital control unit, the boiler can also be controlled from the living space. Operation could hardly be easier than with the 5-inch colour touchscreen which, due to its high class design, can be integrated into any living space, enabling remote control of the boiler. The intelligent extended control (additional controller) also enables the integration of other control loops as well as boilers, and can therefore be used universally as a room controller, additional controller or cascade control unit.



Vitotrol 350-C with 5-inch colour touchscreen as room controller, additional controller or cascade controller



Vitotrol 350-C – default display of cascade for up to four wood boilers

### Versatile and application oriented

In addition to the control loops that are part of the boiler control unit, the Vitotrol 350-C also enables the integration of 20 further control loops, based on controller modules. These are connected via CAN bus and can be freely configured, for example as a heating circuit, DHW heating, heat pipeline or buffer cylinder as a substation. This ensures versatile application and the implementation of complex as well as extensive control scenarios. Furthermore, data exchange can be activated via Modbus TCP, for example in order to integrate a higher ranking BMS.

### Flexibility and reliability

When it comes to heat provision for larger properties, it is important to cover the fluctuating seasonal heat demand economically and efficiently. With the Vitotrol 350-C, Viessmann offers an intelligent solution in the form of a cascade control unit for wood boilers, whereby up to 4 wood boilers can be connected in a cascade. In addition, a peak load boiler (e.g. oil/gas boiler) can be enabled via the master boiler. This can also be an existing system. In this case, the benefit of a cascade lies in the large modulation range. Almost every output range between 2.4 and 404 kW can therefore be displayed. In addition to the combination of different boiler outputs and fuels

(pellets and woodchips), the increased reliability of supply that the cascade control unit provides is very impressive. This is because multiple boiler operation ensures a reliable heat supply. In this way, necessary maintenance work can be carried out without heating interruptions.

### Take advantage of these benefits

- Operating convenience through intuitive operation
- Cascade control for 2 to 4 wood boilers in the output range from 2.4 to 404 kW
- Combination of different boiler types, output ratings and fuels for increased flexibility
- Optimum matching to the seasonal heat demand due to a wide output range
- Extremely reliable supply due to multiple boiler operation (redundancy)
- Maintenance work possible without heating interruptions
- Economical and efficient solution for supplying larger properties
- Integration of a peak load boiler (oil/gas boiler, including existing systems)
- Balanced utilisation of the boilers by monitoring the hours run
- Integration into higher ranking control unit via Modbus TCP
- Extended charge indicator for the heating water buffer cylinder

## It's that easy to save energy

### Enjoy energy savings, comfort and security



Vitoconnect 100 with connections for the plug-in power supply unit (left) and for data connection

**5-year guarantee\***  
at the system start up/  
connection

\* Requirements under  
[www.viessmann.de/5-jahre-garantie](http://www.viessmann.de/5-jahre-garantie)

New possibilities of heating control via the Internet are provided by the ViCare app. By means of the simple graphical interface of ViCare, the heating can be operated intuitively.

#### Saving energy automatically

The system is designed to control a heating circuit. Using the touch feature, the desired room temperature is selected and you switch by finger tip between normal and party ("warm for a long time") mode.

When you leave the house ("On the go"), it also just takes a command to reduce the heating system to a lower temperature, thereby saving energy.

If you want to program different switching times for each day, you'll learn to appreciate the assistance function.

A separate button on the home screen also displays numerous tips for saving energy.

#### Overview of system status at a glance

The user can see at a glance whether the operation of the heating system is in the green zone.

A yellow box informs about an upcoming maintenance and at red, the contact details of the specialist engineer are automatically displayed.

The contact data of the heating engineer is stored for this purpose. Of course, the system operator will decide whether he wants his heating monitored by the specialist engineer via the specially developed Vitoguide app.

#### Internet interface Vitoconnect 100

Vitoconnect 100 is the interface between the boiler and ViCare. It is directly connected via a cable to the Vitotronic control. A plug-in power supply unit is included in the delivery. The only ten centimetres large adapter is intended for mounting on the wall.

The module is connected to the internet and registered via Plug & Play. All it takes is scanning of the enclosed QR code with the smartphone. Vitoconnect 100 is compatible with mobile devices and operating systems from iOS 8.0 and Android 4.4. Control-LEDs indicate the data communication between the heat generator and the Internet.



**Safety**

**Heat and the feeling of safety**

- See at a glance whether everything is in the green zone
- Yellow informs about a pending maintenance
- At red, the address of the stored specialist engineer is displayed



**Save costs**

**Just adjust to the temperature that feels right – save costs when no-one's home**

- The heating system is easy and convenient to operate
- Store daily schedule and automatically save energy costs
- Set the basic functions with the push of a smartphone button

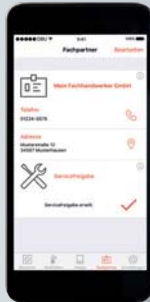

**Carefree**

**The direct line to the specialist engineer – in case you ever need it**

Simply store the specialist engineer

- Fast and effective help – the specialist engineer has all the important information
- All-round carefree package for safety and maintenance

Simply download the app and click "discover ViCare" on the home screen of the app – and get started, without heat generator and Internet.



## Storage and supply systems for pellets

### Robust room discharge for woodchips or pellets

A bottom agitator with two leaf spring arms fills a screw conveyor channel let into the floor. The agitator and screw conveyor are designed for robust operation and high torque. This safeguards a trouble-free and reliable woodchip discharge, no matter in what form. The stable torque support protects the gearbox against overloads and ensures consistently smooth and quiet operation.

### For wood pellets

#### Very quiet supply screw conveyor with low power consumption

The supply screw conveyor is made from hardened steel (chrome-nickel steel) and is characterised by its high torsional strength, resilience and very low friction losses. Outside the pellet store, the feed pipe is made of polished chrome-nickel steel.

### Flame-proof boiler feed with dispensing hopper

The solidly constructed feed screw conveyor made from high temperature-resistant chrome-nickel steel charges the fuel – wood pellets or woodchips – into the combustion chamber in accurately metered lots. Located above the screw conveyor is a dispensing hopper with light guard that determines the level of the separating fuel layer. This fuel barrier prevents an exchange of gases and consequently fuel burn-back. A second burn-back protection device takes the form of a tested shut-off gate. This spring-loaded slide valve opens during the heating phase and closes automatically afterwards or in the case of a power failure.

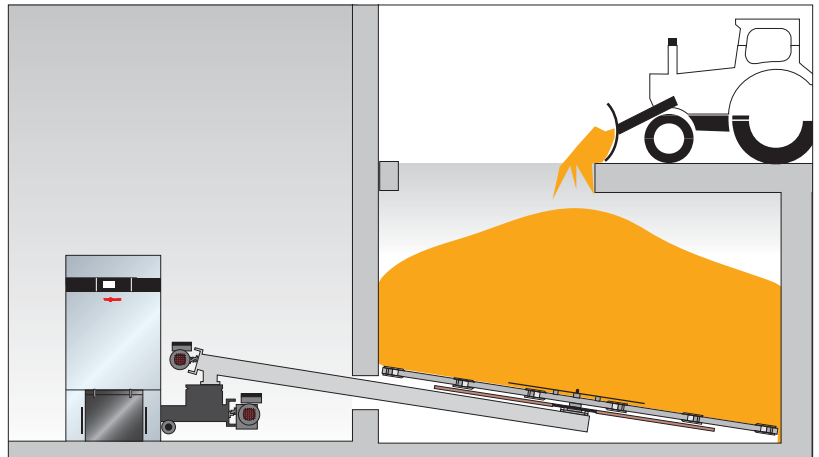

Fuel storage for woodchips or pellets with robust agitator discharge system

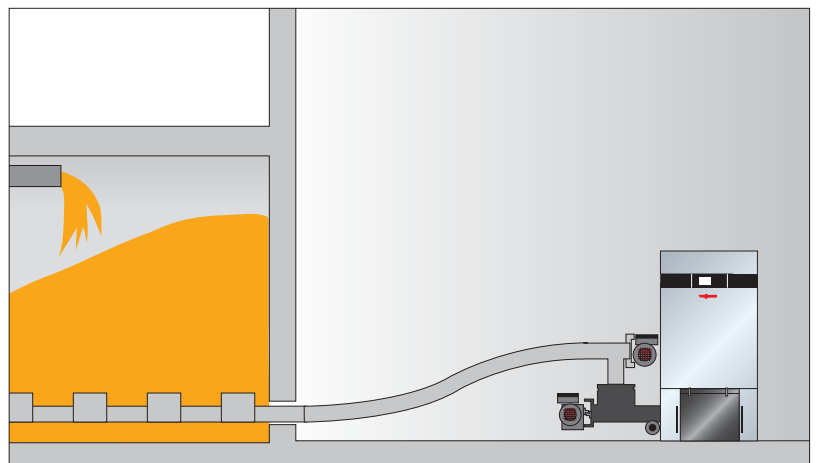

Fuel storage for wood pellets with quiet and energy saving plastic supply screw conveyor



## With Viessmann trade partners, you're in good hands

Viessmann's success is built on close proximity to its trade partners. Anyone who chooses Viessmann can benefit automatically from their specialist expertise.

Advice and support on sales, installation and customer service are available exclusively from Viessmann trade partners, who receive regular training at the Viessmann Academy and have an in-depth knowledge of all the company's products.

### Some service examples

- Free, no-obligation and individual advice, even on site
- Free Energy Economy Check
- Clear calculation of heating cost savings after modernising your heating system – including systems combined with solar collectors, of course
- Calculation of the payback period, after which the new heating system will have paid for itself through energy savings

- Calculation of the actual heat and DHW demand for a household or property
- Information on the most viable combination of a new heating system with a solar thermal system for central heating backup and DHW heating
- Up to date information about public subsidy programmes that could help to finance a new heating system and solar thermal system
- Support in applying for subsidies

#### **Technology from Viessmann – subsidies from the public purse**

With Viessmann, it's not only the running costs that you save. Energy saving and environmentally responsible heating technology is also financially supported by local, regional and national bodies, as well as by your local power supply utility. There are a number of different subsidy programmes, including some that vary by region.

Up to date information is available on the internet at [www.viessmann.de/foerderprogramme](http://www.viessmann.de/foerderprogramme)

#### **Attractive finance – invest now and save on heating costs immediately**

Viessmann's finance model avoids red tape. The fast and reliable process makes modernisation projects easier, and keeps financial planning flexible. The particular advantage is that with Viessmann's favourable terms, savings on heating costs are generally significantly higher than finance costs.

#### **Please note:**

Applications for subsidies and finance must be made before the heating and/or solar thermal system is purchased. Subsidies and finance agreements cannot be arranged retrospectively. Full details on the Viessmann finance model are available from your local trade partner.



Reliable and competent advice from Viessmann employees and trade specialists on site and at their offices

#### **Terms and conditions to shout about**

If you invest now in a new heating system for your property, you may be eligible for an attractive finance package from Viessmann in conjunction with CreditPlus bank: just 3.99 percent\* effective APR.

\* Over 24 months



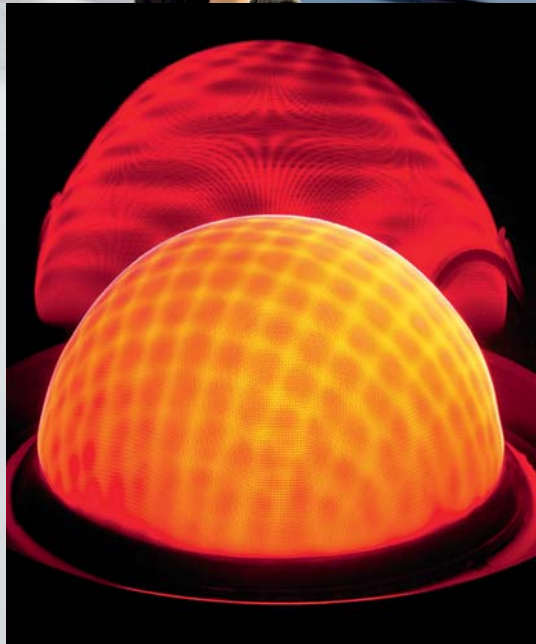



# The company

Viessmann is one of the leading international manufacturers of efficient heating, industrial energy and refrigeration systems.

### Acting in a sustainable manner

As a family business Viessmann takes the long view and places great value on acting responsibly; sustainability is firmly enshrined in the company's principles. For Viessmann, sustainability in action means striking a balance between economy, ecology and social responsibility throughout the company; meeting current needs without compromising the quality of life of future generations.

With its strategic sustainability project, Viessmann demonstrates at its own head office in Allendorf (Eder) that the energy and climate policy goals set by the German government for 2050 can in fact be achieved today with the help of commercially available technology.

### The Viessmann comprehensive range

As environmental pioneer and technological trailblazer for the heating sector, Viessmann has for decades been supplying exceptionally clean and efficient systems for heating, refrigeration and decentralised power generation. Many of the company's developments are recognised as heating equipment milestones.

### Practical partnership

As part of its comprehensive range, Viessmann also offers a wide selection of complementary services. These services include a comprehensive training and further development programme for trade partners at the well equipped training facilities of the Viessmann Academy.

With its new digital services, Viessmann offers innovative solutions such as the operation and monitoring of heating systems by smartphone. Users benefit from greater reassurance and convenience, whilst contractors can keep a constant eye on the systems for which they are responsible.



German Sustainability Award for Production/Brand/Resource Efficiency



Energy Efficiency Award

## Viessmann Group

### Company details

- Established in: 1917
- Employees: 11,600
- Group turnover: 2.22 billion euros
- Export share: 56 percent
- 22 production companies in 11 countries
- 74 countries with sales companies and branches
- 120 sales offices worldwide

### The comprehensive product range from the Viessmann Group

- Boilers for oil or gas
- Combined heat and power generation
- Hybrid appliances
- Heat pumps
- Wood combustion technology
- Biogas production plants
- Biogas upgrading plants
- Solar thermal
- Photovoltaics
- Accessories
- Refrigeration systems



Viessmann Werke GmbH & Co. KG  
35107 Allendorf (Eder)  
Telephone +49 6452 70-0  
Fax +49 6452 70-2780  
[www.viessmann.com](http://www.viessmann.com)

Your trade partner:

9449 591 - 7 GB 02/2017

Copyright Viessmann  
Duplication and alternative use only with prior written consent.  
Subject to technical modifications.